

The following pages are a guide designed to provide 3M TCM digital graphic license plate customers with information relating to digital graphic license plate artwork, design and production.

PRINTING CAPABILITIES

To better understand the design process, the digital license plate printing process will be explained to better enable the designer to understand the purpose for the 3M TCM design specifications. The digital license plate printing process is unique and as such requires different design specifications than those used in conventional printing.

Medium

All 3M digital license plates are printed on reflective sheeting that is covered with tiny glass reflective beads. The sheeting is not as dimensionally stable as paper and stretching may occur. This medium also has some limits in thermal transfer graphic printing due to the high heat required to transfer the ribbon media to the sheeting.

Registration

Registration of each of the four color stations is plus or minus 2 mils (.002) per color. The sheeting has a tick mark used for printer registration. The printer uses a Top-Of-Form (TOF) sensor to read the tick mark and locate the graphic. The registration of the printer to the tick mark is plus or minus .05".

Coverage

The coarseness of the sheeting may cause halftones over 75% tint value to fill in. Halftones under 5% tint value may not print at all. Most images are printed at 60-75 lpi, but some halftones may have to be printed using 40-55 lpi for optimum coverage and printability. The designer, in certain instances, may need to adjust the separation angles, the separation technique, and/or dot shape to optimize printing of the design. Thin lines less than 1/32nd of an inch may break up or print unevenly.

Colorants

The colorants used for digital license plate printing are resin ribbons manufactured to be UV fade resistant. These ribbons produce colors that are transparent, in order to meet reflectivity standards. The digital license plate printing process does not use the Pantone color match system. For optimum color matching, colors should be selected from the 3M Digital Graphic License Plate Colors Book. Opaque, Metallic and Fluorescent Pantone inks (numbers 801-877) are not available for license plate printing.

DESIGN PARAMETERS

Keep the following parameters in mind before starting any license plate design.

Size

The finished plate size for digital license plates is 12 W x 6 H inch in dimension. Designs for use in the United States, Canada and Mexico must fit into an 11.4375 W x 5.4375 H inch rectangle with radius corners sized to match the debossing rim in the blanking press. The resulting 1/4 inch margin is needed to ensure acceptable finished license plates, given the requirements of the sheeting and the production processes. Bolt holes are .3125 inches in diameter and each are spaced (to bolt hole center) +/- 3.5 inches horizontal and +/- 2.375 inches vertical from the center of the plate. Check with the local regulatory agency for specific plate geometry and design requirements (i.e. size and location of the alphanumeric, sticker pockets, etc.) See Figure 1 for a graphic representation of these parameters.

Line Art

Avoid thin lines under 1/32nd of an inch thick. Intricate solid shapes are acceptable, however, a loss of detail may occur. Design elements (shapes) smaller than .008 x .008 inches and/or .008 inches in any dimension may fail to print.

Color

Typical 4 color designs should be designed and setup using the CMY colors only. The 4th color station, typically the black color, will usually be used for a separate spot color for printing the alphanumeric. While halftones and graduated tones can be used, a shift in these tones may result, due to the unique properties of the reflective materials, ribbons and printing process.

Due to the excessive heat that could be generated by producing plate designs with large color fill areas, the graphic design should be limited in the amount of color saturation. If designs of large color fill areas must be used, the number of plates able to be printed at a time may be limited in number. For best results, the following guidelines are suggested:

- If the background graphic is to fill the entire 5.5" x 11.5" area, the tonal value for any one color covering the entire area should not exceed 25%.
- The total tonal value of all colors should not exceed 50%. This can be found through Adobe PhotoShop. After bringing the design into Photoshop, select the bilinear image resample and then reduce the size of the image to 1 pixel. Use the magnify tool to enlarge the pixel. Make sure the image is in CMYK mode. Place the Magic Wand tool over the pixel and add the % values in the Info box. Any total over 50% could potentially prove to be troublesome over extended runs.

The designer should seek to balance the use of color in the design across the license plate. Designs with color on one side of the plate but not on the other side, or uneven color distribution across the plate, could cause ribbon wrinkling during printing.

Graphic Placement and Legibility

Since size and spacing of the alphanumeric vary, check with the local regulatory agent for exact specifications. Avoid heavy coverage of colorant in the alphanumeric areas. Heavy coverage in these areas reduces legibility for law enforcement. Design elements (text and logos) dark in color should be spaced at least 1/4th of an inch away from the alphanumeric.

Trapping

Because of the transparent properties of the thermal transfer ribbons, trapping between colors and halftones is not recommended.

COMPUTER CAPABILITIES

3M TCM uses Adobe Illustrator and Adobe PhotoShop on both Macintosh and PC computers and CorelDraw on PC computers.

Compatibility

3M TCM accepts Adobe Illustrator files, Adobe PhotoShop files, CorelDraw files and Adobe Acrobat files. All placed or parsed bitmap files must be included separately. For Adobe Illustrator files, save in the Illustrator 6.0 .ai format. For Adobe PhotoShop files, save in the .psd format. Save with elements on separate layers and do not flatten before saving. For CorelDraw files, save in the .cdr format and for Adobe Acrobat files, save in the .pdf format. Include all placed or embedded bitmaps as separate files. All files, in any format, must have anti-aliasing and color profiles turned off.

If you believe there may be a compatibility issue between your system and 3M TCM's, also send black and white color separation printouts on paper or film, or composite prints, at 100%. 3M TCM will scan and recreate artwork to match the original design. Before making printouts, fill all halftones 100% so that its shape can be clearly delineated. Include a composite print of the design at 100%. Specify all fonts used, color call outs, and halftone tint values if halftones are used. If photographs are incorporated into the design, please submit. 3M TCM will scan them for placement into the design.

Do not use compression software of any kind for vector files.

3M TCM does not use 3D or CAD software.

ELECTRONIC DESIGN

The following guidelines are for customers sending electronic files.

All license plate designs are completed in vector form (Adobe Illustrator or CorelDraw), with placed photographs if any. 3M TCM prefers that customers send original photographs and/or traditional illustrations for scanning and converting to spot color. 3M TCM will accept Adobe PhotoShop files or tiff files of scanned or created material. However, the resolution cannot be increased. Acceptable disk formats are listed on page 3.

Vector Artwork

Fonts, logos, halftone areas, gradient fill areas, and line art in general, should be constructed in a vector drawing program such as Adobe Illustrator or CorelDraw. This makes file sizes small, editing, trapping, and color separation easier. For example, crisp type done in a paint program would need to be at 300 dpi resulting in horrendous file sizes.

Convert all fonts to vector form by using Create Outlines or convert text to paths according to whatever vector program is being used. Or send the True Type Font used in the design on the disk with the design.

Bitmapped Artwork

Bitmapped artwork is any image such as a scanned photograph or traditional illustration that is in pixel form, commonly used or created in a paint program such as Adobe PhotoShop or Corel Paint. Bitmapped artwork can be successfully incorporated into a license plate design using a variety of methods. Again, 3M TCM prefers that the customer send continuous tone photographs and/or traditional illustrations for scanning, clipping path creation, spot color conversion, placing, and color separating. 3M TCM can accept scanned or created images from the customer with a resolution of 300dpi at 100% size. Do not use any anti-aliasing in PhotoShop. This includes tools such as the magic wand, paint bucket, lasso, and marquee tools. Anti-aliasing will only result in a blurry image when printed.

3M TCM will scan and convert any line art on paper or film.

3M TCM will not scan halftones for reuse.

Customers sending in pictures for scanning should keep in mind that photographs and/or illustrations from previously printed materials such as books, magazines, and brochures will not scan well due to halftone dot patterns. Scanning such material may constitute a copyright violation for which the customer, not 3M TCM, will be held liable. Do not send web site images or printouts thereof. Web site images are typically at the lowest possible image quality (8-bit color at 72dpi). These images are not usable.

Since color photographs and illustrations will be converted to CMY and one spot color, this will limit the number of colors to four. The finished result is basically a compilation of monochromatic (single spot color) areas. Save bitmapped artwork in the tiff file format. 3M TCM does not recommend image compression. If image must be compressed, use only LZW compression. JPEG compression permanently degrades the image.

Please include a hardcopy or detailed layout for each design. This can be color, black and white laser prints, or drawn layouts. Include color call outs, identify the fonts used, and specify halftone values. This avoids any confusion concerning the design and its elements.

ELECTRONIC DISK FORMATS

Floppy Disks: DS HD 1.4 MB PC formatted

IOMEGA: 100MB ZIP PC formatted

Compact Disk (CD)

FIGURE 1

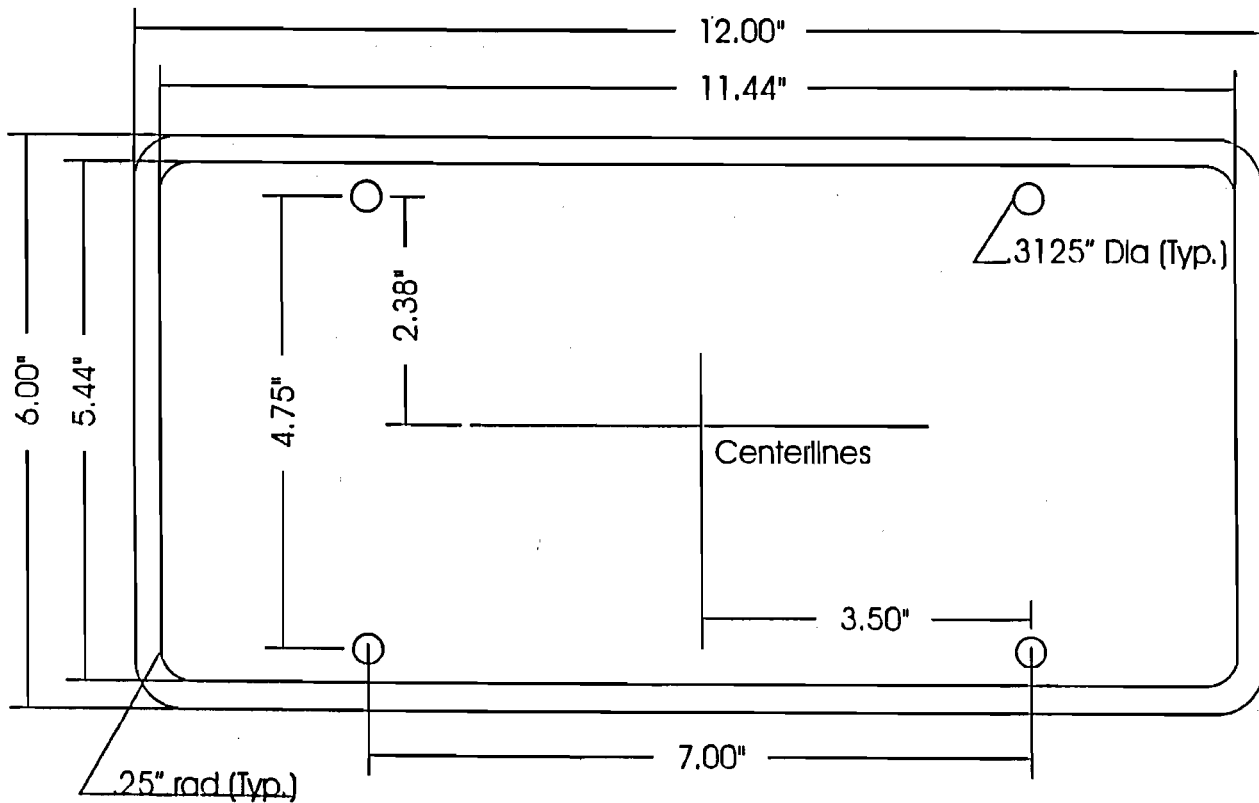

Designated design areas available for Specialty License Plates (see diagram on the next page):

1. "Montana" is printed in capital letters. Size of "Montana" is 1" H x 6" W and will be placed at least .25" from the top of the plate to allow for rimming. "Montana" can be moved right or left in any combination.
2. Alphanumeric characters will be located in a 2.5" H x 8.5" W area centered height-wise on the plate. The characters can be moved left or right in any combination.
3. Registration tabs are located on the bottom right-hand side of the plate and are 1-1/4" H x 1" W. This dimension includes both the month and the year tab. Designs may be in this area but the tabs will cover any design.

Overall:

All areas not specified on the above plate are available for design, however any design that is in areas 1, 2 or 3 above must be light in color so as not to conflict with readability of the plate.

12.00"

11.44"

1

MONTANA

6"

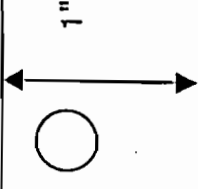

1"

2

AAA-000

6 1/2"

6.00"

5.44"

2 1/2

Centerlines

2"

8 1/2"

3

1 1/4"

Registration
tab

7.00"

.25" rad (Typ.)

Scale 1" = 1"